



IRTA DUPLO & MARKETING
THE NEW PRODUCTIVITY-TIME DIMENSION

It's the same!

**Double production
or produce in half the time**

In the case of the IRTA DUPLO packaging unit we can easily confirm the above statement because when it makes small bags, it makes them two at a time! It goes without saying that this machine will take your business into a new dimension.

In other words, you can have the peace of mind of being able to produce your orders in half the time or keep up normal production times and cater for twice as many orders. Whatever method you choose you can always rely on the quality-reliability-price factor which define all our machines.

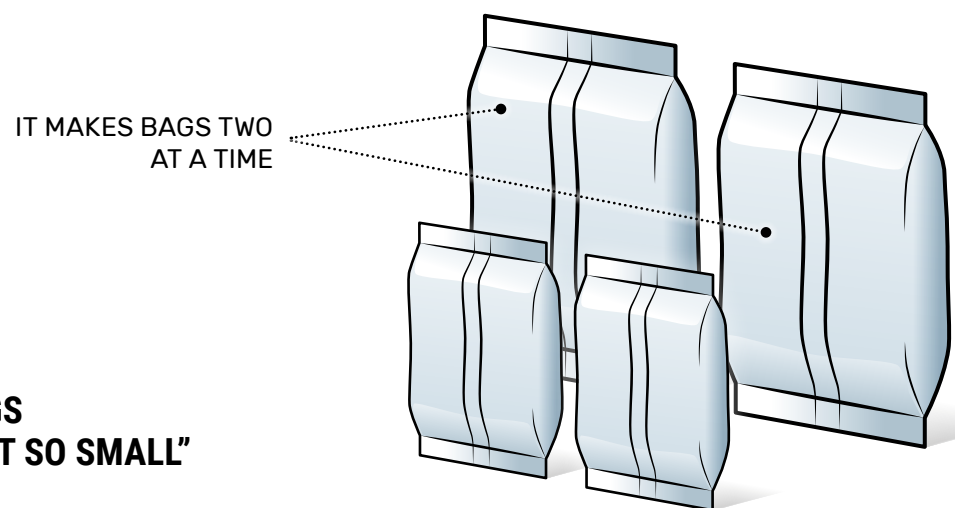

BAGS "NOT SO SMALL"

The ability of this robust, compact machine to adapt to any kind of small product and consequently to adjustments in size, will allow you to flood the retail market with your products in record time as well as reaching other niche markets.

**MAKE BAGS
FROM
50 x 40 mm
TO
120 x 200 mm**



LEADERS IN THE MANUFACTURE OF VERTICAL PACKAGING MACHINERY

**WE DESIGN, DEVELOP AND MANUFACTURE
MACHINERY, ACCESSORIES AND COMPLEMENTS**

ADAPTABLE TO ANY KIND OF PRODUCT

VAST RANGE OF OPTIONAL EQUIPMENT AVAILABLE

MAXIMUM FINISH QUALITY GUARANTEED

COMPONENTS FROM LEADING WORLDWIDE MAKES

OWN R&D&I DEPARTMENT

MADE-TO-MEASURE SOLUTIONS

100% OWN DEVELOPMENTS

INSTALLATION OF COMPLETE PACKING LINES

TURN-KEY PROJECTS



IRTA DUPLO

MULTIFORMAT VERTICAL PACKAGING UNIT

DOUBLES PRODUCTION IN THE SAME AMOUNT OF TIME



HIGH OUTPUT IN SMALL BAGS

Proudly Distributed by TDI Packsys



TDI Packsys is a premier provider of inspection solutions and packaging automation systems. Our expert team is dedicated to delivering state-of-the-art solutions that meet your budget. Contact us to see how we can help optimize your operation.

(877) 834-6750
sales@tdipacksys.com
www.tdipacksys.com

MAKE 2 BAGS PER CYCLE
MAXIMIZING PRODUCTION TIME

HIGH PRODUCTIVITY

OPTIONS FOR
DISCHARGING PRODUCT

VOLUMETRIC DOSIFIER

MULTIHEAD WEIGHER



IRTA DUPLO BAGS TWO BY TWO

Its two forming tubes make two independent bags in each cycle, reducing production time by half.

MULTIFORMAT PACKAGING UNIT

IRTA DUPLO

240 bags
in just one minute

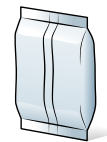

Almohadilla
Pillow Pack

MEASUREMENTS

Adjustable width
50 mm - 120 mm

Adjustable length
40 mm - 200 mm



Especially suited for packaging all kinds of small products such as sunflower seeds, fruit gums, snacks, nuts.....



SPECIALLY DESIGNED FOR



Candy



Sunflower seeds



Snacks



Nuts



Quinoa

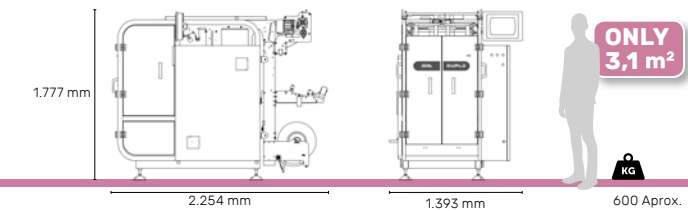

STANDARD FEATURES

STANDARD FEATURES	IRTA DUPLO
Finish	Stainless steel
Maximum Output (240 bags/min)	120 Cycles/min.
Energy Consumption(Nominal Max Value)	5,5 KVA
Mains Voltage	230 / 400 Vca
Type of Protection	IP 35
Servomotors	Rockwell
Pneumatics	Festo
Vacuum Pump	Becker
Air Consumption	12 NI / Cycle
Movement Management & Field elements	Bus Ethernet
Control over shafts with Implemented Motion Functions	Yes
Temperature control, Welding Time & Pressure	Yes
Fast reel change with or without suction	Yes
System for centering printed film	Independent
LAN Ethernet Connection	Yes
Reel. Width / Max Diameter	550 / 400 mm
Reel Spindle	75 mm
Film pulling system	Belt drive with vacuum
End of Film Warning	Yes
Color Touch Display	10"
Interface Languages	E / EN / DE



EXPANSION KITS

- Modified atmosphere injection
- Constant heat jaws for PE film and high speeds
- Elimination of static electricity from film
- Bag vibrator
- Strings or double package
- Euro-lock / Euro-hold
- Coders, labellers...
- Product exit belts

OPTIONS FOR DISCHARGING PRODUCT

VOLUMETRIC DOSIFIER



MULTIHEAD WEIGHER



We manufacture to your specifications

Contact our R+D Department and let us know your needs.